

Professional 4" Desktop Monitoring System

# nEar 04

**User's Guide**





CAUTION: TO REDUCE THE RISK OF ELECTRIC SHOCK, DO NOT REMOVE COVER (OR BACK). NO USER SERVICEABLE PARTS INSIDE. REFER SERVICING TO QUALIFIED SERVICE PERSONNEL.

**WARNING:** TO PREVENT FIRE OR ELECTRIC SHOCK, DO NOT EXPOSE THIS APPLIANCE TO RAIN OR MOISTURE

**CAUTION:** TO PREVENT ELECTRIC SHOCK, DO NOT USE THIS (POLARISED) PLUG WITH AN EXTENSION CORD, RECEPTACLE OR OTHER OUTLET UNLESS THE BLADES CAN BE FULLY INSERTED TO PREVENT BLADE EXPOSURE

**NOTE:** Some **ESI** products are equipped with dual or multi-voltage transformers (which is indicated on the back panel). Before you plug in the power cord, please check the AC voltage selector on the back panel of this product and make sure the voltage selector is set correctly.



The lightning flash with arrowhead, within an equilateral triangle, is intended to alert the user of the presence of uninsulated "dangerous voltage" within the product's enclosure; that may be of sufficient magnitude to constitute a risk of electric shock to person



The exclamation point within an equilateral triangle is intended to alert the user of the presence of important operating and maintenance (servicing) instructions in the literature accompanying the appliance.

**CAUTION:** The apparatus shall not be exposed to dropping or splashing and that no objects filled with liquids, such as vases, shall be placed on the apparatus.

## INDEX

<b>1. Introduction</b> .....	<b>4</b>
<b>2. Basics &amp; Installation</b> .....	<b>4</b>
Unpacking / Handling .....	4
Connection .....	4
<b>3. Placement of the speakers</b> .....	<b>5</b>
Positioning .....	5
Orientation .....	6
Comments .....	6
<b>4. Technical Data</b> .....	<b>6</b>
Specifications.....	6
Block Diagram.....	7
Rear Panel.....	8
Front Panel / Side View .....	9
<b>5. General Information</b> .....	<b>9</b>

**ESI - Copyright © 2005 - 2007**

Revision 2, August 2007

**[www.esi-audio.com](http://www.esi-audio.com)**

## 1. Introduction

Congratulations on your purchase of the ESI nEar04.

The nEar04 desktop near field monitors have been developed especially for high level home studios and special project studios. nEar04 have been designed to overcome all the typical limitations of conventional small sized monitoring speakers providing a special 4" polypropylene curved woofer cone and a 1" natural silk dome tweeter. Despite the small size, nEar04 still provide reference level sound quality and enough power for audio monitoring in a digital audio production environment.

## 2. Basics & Installation

For optimal performance of nEar04, read the instructions in this manual thoroughly and carefully before you are using the speakers.

### Unpacking / Handling

To remove the monitors from the carton its best to turn the package carefully upside down on the floor or on a table and then lift the carton vertically up slowly to leave the monitors resting in the packaging foam. Make sure that you don't grab the speaker driver units on the front to avoid damage. Now check the monitors for signs of damage that might have occurred in shipping. In the unlikely event of this, please contact the reseller of the product immediately. Be careful when you remove the packaging foam. Please keep all packing materials.

### Connection

High quality balanced or unbalanced audio cables are recommended for input connection. The monitors typically connect to the line level output of a mixing console or to a computer audio card. One monitor has to be connected to power connection, the other monitor is connected via the supplied speaker wire to the first monitor. Make sure the power of the main monitor is switched off before you connect any audio cables. Also turn down the volume initially.

### TRS balanced / unbalanced connection

Connect male side of TRS balanced or unbalanced cable to the TRS input of nEar04 – as show on the picture above (the picture shows the left audio channel connection only). Do this for both the left and right audio channels with separate cables. Make sure the power cable is connected as well.

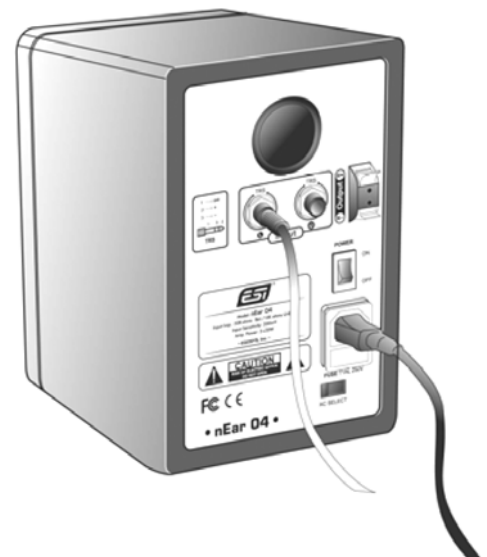

### Second speaker connection

After that, connect the second speaker with the included speaker wire. Make sure the + / - (red / black) connectors are not swapped with each other to avoid phase problems during playback. The complete setup will then look like shown on the following picture:

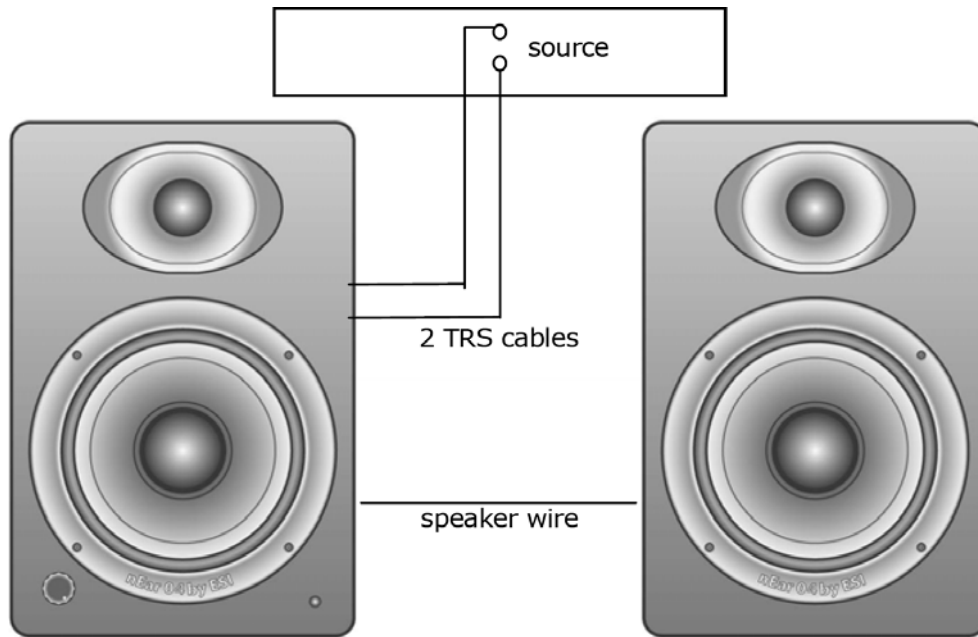

### 3. Placement of the speakers

The placement of monitoring speakers is very critical and can compromise their performance. This is a general rule for every loudspeaker. To monitor with nEar04 utilizing their maximum capabilities, an appropriate listening environment and a correct placement are important.

#### Positioning

In principle, two units and the listener should be positioned or aligned in a regular triangle form. Please refer to the following diagram to understand how to position your monitors.

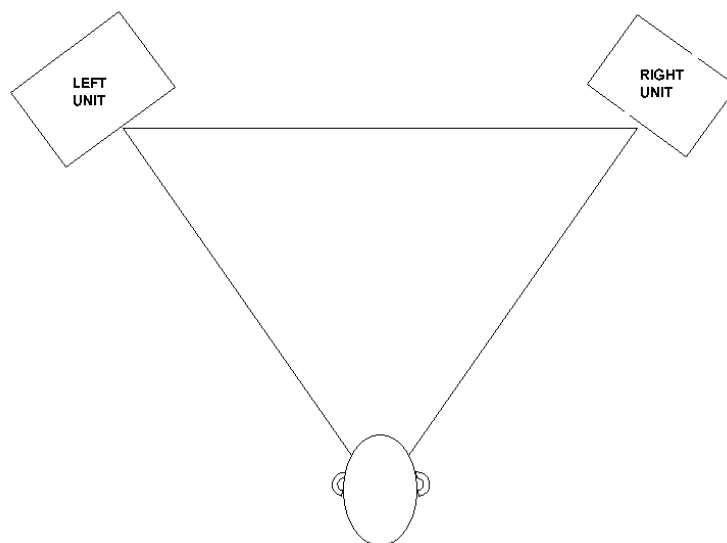

The height of the units, more precisely the top of the woofer, is recommended to be at the ear level of the listener. Keep in mind that in a typical monitoring environment, you are sitting in front of your workstation. Refer to the following diagram:

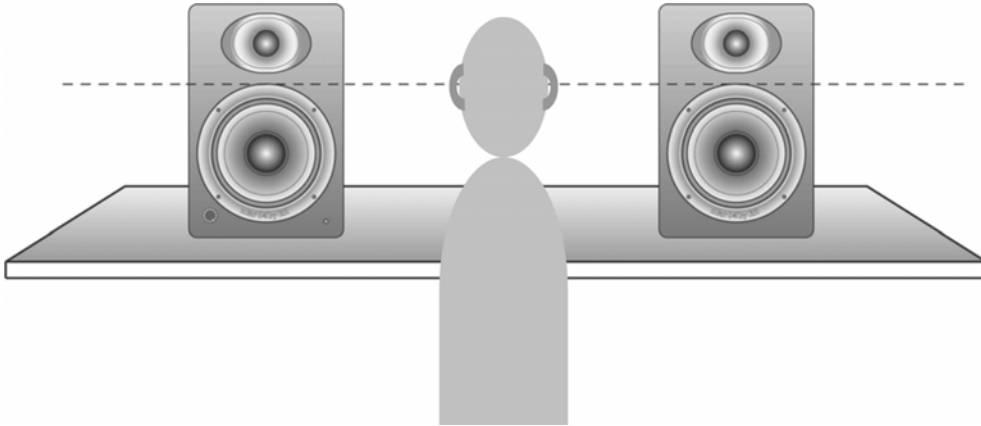

### Orientation

It's very important to place the nEar04 vertically. Never place them horizontally.

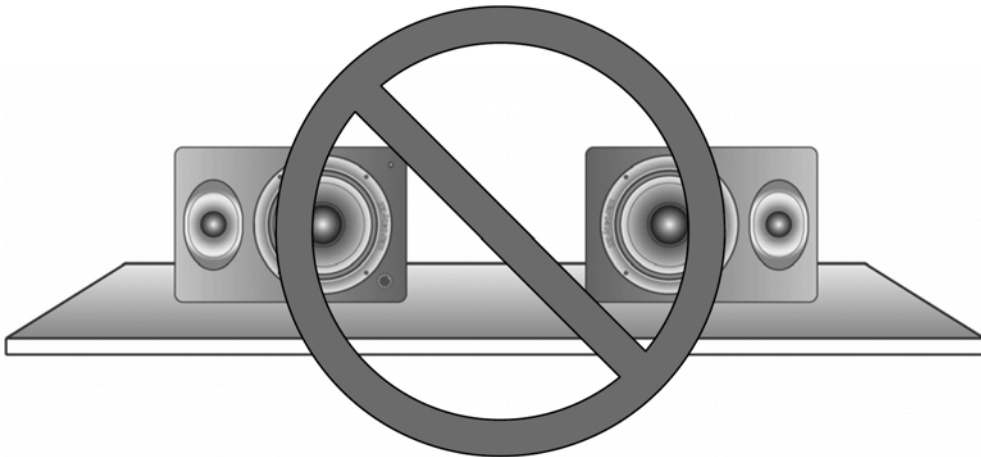

### Comments

Please also make sure to not place any obstacles that may block the flow of air or that could generate sound reflections (especially highly reflective material including glass or metal) in front of the speakers. Also, don't put plants in pots on top or too close to your monitoring speakers.

## 4. Technical Data

Please note that technical specifications are subject to change without any prior notice. The specs given in this manual are up-to-date at the time of the creation of this document.

### Specifications

- **Type:** Dual amplified Bookshelf (one side passive)
- **LF Driver:** 4 inch Polypropylene curved cone with high temperature voice coil and damped rubber surround.
- **HF Driver:** 1 inch magnetically shield natural Silk Dome.
- **Frequency Response:** 100Hz - 22kHz
- **Crossover Frequency:** 4.1kHz
- **Amplifier Power:** 20W x 2

- **S/N Ratio:** > 100dB below full output, 20 kHz Bandwidth
- **Input Connectors:** 2 x TRS Balanced/ Unbalanced Input Connectors (L/R)
- **Polarity:** Positive signal at + input produce outward LF cone displacement
- **Input Impedance:** 20k ohms balanced, 10k ohms unbalanced
- **Input Sensitivity:** 200 mV input produces full output with Volume control at maximum.
- **Protection:** RF interference, output current limiting, over temperature, turn-on/off transient, subsonic filter, external mains fuse.
- **Indicator:** Power ON/OFF indicator on front panel
- **Power Requirements:** Factory programmed for either 115V ~50/60Hz, or 230V~50/60Hz power via detachable 3 circuit line cord.
- **Cabinet:** vinyl laminated MDF
- **Dimension:** 206mm(H) x 136mm(W) x 149mm(D)

## Block Diagram

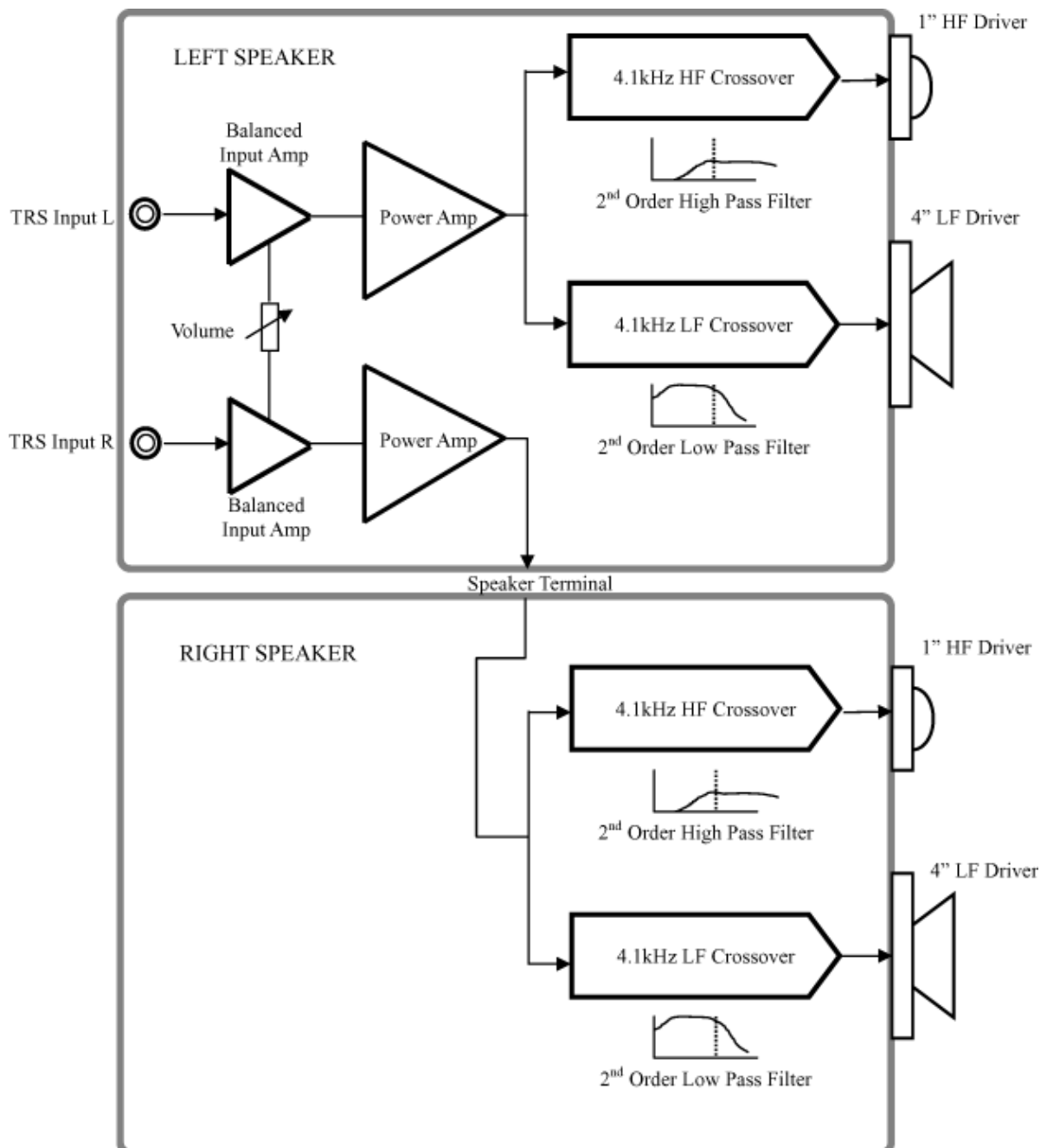

Rear Panel

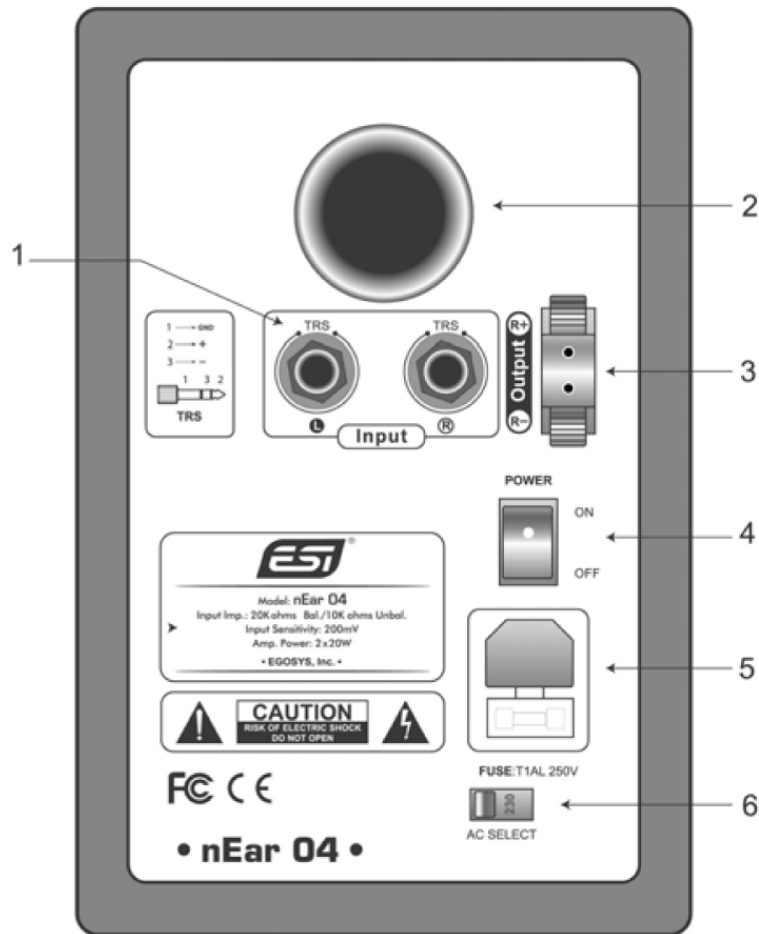

**1. TRS input** – these jacks accept TRS input connections, either balanced or unbalanced. For balanced connections, a 3-conductor TRS plug is necessary. The TRS input is wired like this:

INPUT SIGNAL	TRS CONNECTIONS
+	Tip
-	Ring
Shield	Sleeve

Unbalanced wiring works with either a 2- or 3-conductor TRS connector. A 2-conductor TRS plug (or sometimes also just called TS plug) automatically grounds the minus signal input, whereas a 3-conductor TRS plug wired unbalanced provides the option of leaving the minus open or grounded. We recommend that you ground the unused input.

**2. vent port** –nEar04 is a vented box speaker system with a vent port on the rear panel. Make sure you are not blocking the vent port (i.e. by putting the speaker too close to a wall) or the sound colour will be changed.

**3. speaker wire connection** – use these connectors to connect the included speaker wire with the second passive nEar04 speaker.

**4. power switch** – when you push the power switch, nEar04 will be turned on, and –surprise– it will be turned off when you push the power switch again.



**5. power port with ext. fuse** – use this connector to plug in the detachable 3-circuit line cord that connects to the power outlet.

**6. AC selection** – you can select either 110V or 230V AC power according to your local requirements. Make sure this is selected properly before you switch on nEar04 for the first time or your equipment could be damaged.

### Front Panel / Side View

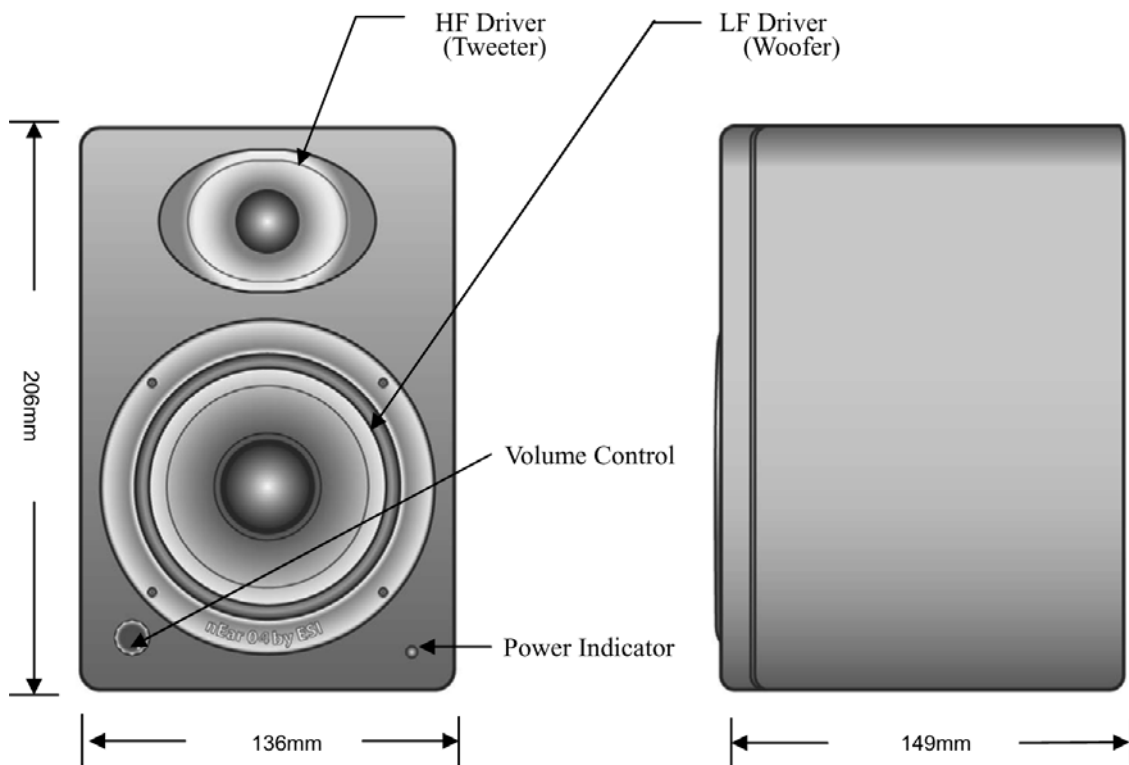

**volume control knob** – use the volume control to set the proper output level of nEar04. Please be careful and never set the volume too high as it could damage your equipment otherwise.

**power indicator** – the LED on the front shows if nEar04 is switched on or not.

Notice: The above picture shows the front panel of the left speaker. The right speaker does not have a volume control knob and power indicator LED.

## 5. General Information

### Trademarks

ESI, nEar and nEar04 are trademarks of Ego Systems Inc. and ESI Audiotechnik GmbH. Other product and brand names are trademarks or registered trademarks of their respective companies.

## Correspondence

For technical support inquiries, contact your nearest dealer, local distributor or ESI support online at [www.esi-audio.com](http://www.esi-audio.com).

## Disclaimer

All features and specifications subject to change without notice.

Parts of this manual are continually being updated. Please check our web site [www.esi-audio.com](http://www.esi-audio.com) occasionally for the most recent update information.

## Declaration of Conformity (for the European Union)

The product described in this manual is manufactured in China by **ESI Audiotechnik GmbH, Brennerstraße 48, D-71229 Leonberg, Germany**. The product is labelled with the CE mark and conform to the protection requirements of the European Electromagnetic Compatibility Standards and Directives. The product is designed and constructed such that electromagnetic disturbances generated do not exceed levels allowing radio and telecommunications equipment and other equipment to operate as intended, and, the product has an adequate level of intrinsic immunity to electromagnetic disturbance to enable operation as specified and intended.

The product is marketed as **ESI nEar04** desktop monitoring speaker.

With reference to regulations in the directives 73/23/EEC, 89/336/EEC, the equipment listed above is covered by this certificate and labelled with the CE mark conforms to the following standards:

EN60065 Safety requirements for mains operated electronic and related apparatus for household and similar general use.

EN55103-1 & EN55103-2 Product family standard for audio, video, audio-visual and entertainment lighting control apparatus for professional use.

This declaration is made by Claus Riethmüller (Managing Director).

Leonberg, Germany

City

17.08.2007

Date



Signature

# SAFETY INSTRUCTION

---

## 1. READ INSTRUCTIONS

All the safety and operating instructions should be read before the appliance is operated.

## 2. RETAIN INSTRUCTIONS

The safety and operating instructions should be retained for future reference.

## 3. HEED WARNINGS

All warnings on the appliance and in the operating instructions should be adhered to.

## 4. FOLLOW INSTRUCTIONS

All operating and use instructions should be followed.

## 5. WATER AND MOISTURE

The appliance should not be used near water – for example, near a bathtub, washbowl, kitchen sink, laundry tub, in a wet basement, or near a swimming pool, etc.

## 6. CART AND STAND

The appliance should be used only with a cart or stand that is recommended by the manufacturer.

**6A.** An appliance and cart combination should be moved with care. Quick stop, excessive force, and uneven surface may cause the appliance and cart combination to overturn.



## 7. WALL OR CEILING MOUNTING

This equipment is not designed for use mounted on a wall or a ceiling.

## 8. VENTILATION

The appliance should be situated so that its location or position does not interfere with its proper ventilation. For example, the appliance should not be situated on a bed, sofa, rug, or similar surface that may block the ventilation openings, or placed in a built-in installation, such as bookcase or cabinet that may impede the flow of air through the ventilation openings.

## 9. HEAT

The appliance should be situated away from heat sources such as radiators, heat registers, stoves, or other appliances (including amplifiers) that produce heat.

## 10. POWER SOURCES

The appliance should be connected to a power supply only of the type described in the operating instructions or as marked on the appliance.

## 11. POWER – CORD PROTECTION

Power-supply cords should be routed so that they are not likely to be walked on or pinched by items placed upon or against them, paying particular attention to cords at plugs, convenience receptacles, and the point where they exist from the appliance.

## 12. CLEANING

The appliance should be cleaned only as recommended by the manufacturer.

## 13. NON USE PERIODS

The power cord of the appliance should be unplugged from the outlet when left unused for a long period of time.

## 14. OBJECT AND LIQUID ENTRY

Care should be taken so that objects do not fall and liquids are not spilled into the enclosure through openings.

## 15. SERVICING

The user should not attempt to service the appliance beyond that described in the operating instructions. All other servicing should be referred to qualified service personnel.

## 16. DAMAGE REQUIRING SERVICE

The appliance should be serviced by qualified service personnel when:

- a) The power-supply cord or the plug has been damaged; or
- b) Objects have fallen, or liquid has been spilled into the appliance; or
- c) The appliance has been exposed to rain; or
- d) The appliance does not appear to operate normally or exhibits a marked change in performance; or
- e) The appliance has been dropped, or the enclosure is damaged.

## 17. POWER LINES

(APPLIES FOR TUNER AND RECEIVERS ONLY)

An outdoor antenna should be located away from power lines.